

ID In.	Ends	W (in.)	H (in.)	Std Weight (Galv)	Galvanized Steel			304SS		
					22ga	20ga	18ga	22ga	20ga	18ga
6	QF	10.12	14.40	14.00	Std			Optional		
8		13.25	18.40	33.00						
10		16.50	22.40	51.00						
12		20.00	27.00	59.00						
13		21.50	30.00	63.00		Std			Optional	
14		23.12	32.80	70.00						
15		24.50	34.00	79.00						
16		26.50	36.40	84.00						
17		27.70	38.00	90.00						
18		29.50	40.00	98.00						
20		32.50	44.40	111.00						
22		35.40	47.50	118.00						
24	38.60	51.50	138.00							
26	Flanged	42.20	55.00	166.00			Std			Optional
28		45.20	59.00	185.00						
30		48.20	63.00	202.00						
32		51.20	67.00	214.00						
34		54.60	71.00	226.00						
36		58.20	74.70	240.00						
38		61.20	79.00	252.00						
40		64.20	83.00	271.00						

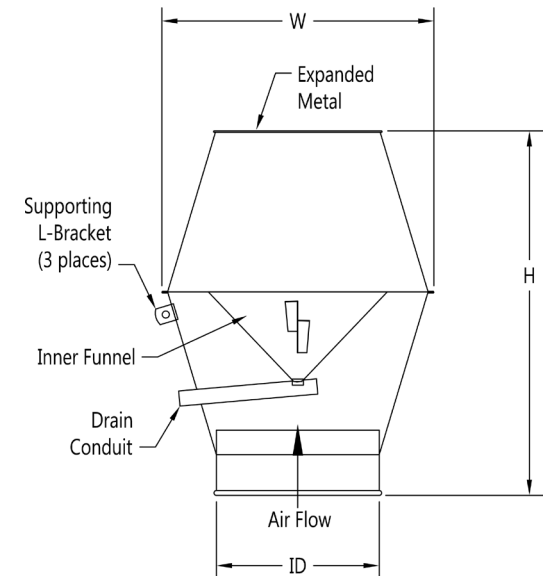

Construction

Top screen: expanded metal, 3/4" square pattern Koga painted black metal.

Collars: Collars have a laser welded longitudinal seam.

Drain conduit: 3/4" dia. used for 6" - 14" ID sizes
 1-1/2" dia. used for 15" - 24" ID sizes
 2" dia. used for 26" - 40" ID sizes

Ends: Standard QF end can be changed to Raw ID (RAWID), Raw OD (RAWOD), No Fitting (NF), Hose Adapter (RAWFLEX), Flat Flange (FFL), Angle Flange (ANGFL), or Van Stone (VANSTONE).

Temperature Rating of Product Components						
° F	QF Jet Cap		Sealants			
1100°	Galvanized Steel	Optional - 304SS	3M Scotch Seal Metal Sealant 2084	Optional - 3M Polyurethane Adhesive Sealant 560	Optional - Rock River Silicone Sealant	Optional - Red Devil HVAC/R High Temperature Silicone Sealant
500°						
400°						
390°						
250°						
194°						
0°						
-40°						
-60°						

Additional Notes
At temperatures ranging between 390° F and 480° F, the zinc-iron alloy layers in galvanized steel will continue to provide a high level of protection from corrosion. However, there may be some peeling, changes in mechanical properties, and reduction in the corrosion protection. Recommended max. service temperature is 390° F.
Rock River Silicone Sealant and Red Devil HVAC/R High Temperature Silicone Sealant are not paintable
304SS: bluing may occur at 800° F and above

Compliance / Rating of Product Components		
Product	Material	Compliance / Rating
QF Jet Cap	Galvanized	ASTM A653 with a G-90 rating
	304SS	Finish meets ASTM A240
	316SS	Finish meets ASTM A240
3M Scotch Seal Metal Sealant 2084	Acetone blend	AAMA Specification 801.1
3M Polyurethane Sealant 560	Polyurethane	ASTM E 162, ASTM E 662, Bombardier SP 800-C
Rock River Sealant	100% Silicone	ASTM C920 Class 25, TT-S-00230C Class A and TT-S-001543A, FDA No 421 CFR 117.2600, conforms to FDA requirements
Red Devil HVAC/R High Temperature Sealant	Silicone	ASTM C920 Class 25, TT-S-00230C Class A and TT-S-001543A, CEBTP 432.6 140-2, Mil Spec 46106A, CGSB 19C9-9B, DIN 18540 Part 2, OREX 150031-2